

10EQ Tandem Axle Equipment

G.V.W.R.	9,900#	AXLES	Two 5,200# EZ Lube w/Electric Brakes
G.A.W.R. (Ea. Axle)	5,080#	SUSPENSION	Multi-Leaf Spring w/Equalizer
COUPLER	Adjustable Forged 2-5/16"	TIRE	ST225/75-15 Load Range D
SAFETY CHAINS	1/4" Grd. 70 w/Safety Latch Hook (2 each)	WHEEL	15 x 6 White Spoke 6 Bolt
JACK	7K Top Wind Drop Leg (Bolted On)	FLOOR	2" Pine
TONGUE	Integral w/Frame	LIGHTS	D.O.T. Stop, Tail, Turn & Clearance
TOP RAIL	None	ELEC. PLUG	7-Way RV
FRAME	8" Channel	FINISH (Prep)	Steel is Cleaned and Etched to Ensure Smooth, High Bond Paint Adhesion.
CROSSMEMBERS	3" Channel	FINISH	Painted with High-Solids Supreme Automotive Grade Enamel and Pin-Striped for a Highly Decorative and Protective Finish.
UPRIGHTS	None		
FENDERS	9" x 72" Double Square Broke, Diamond Plate w/Back		

Standard Features

- Adjustable Forged Coupler
- Safety Chains Attached w/Cold Rolled Eyelets
- 7K Drop Leg Jack
- Lower Jack Support Plate
- Expanded Metal in Bottom of Tongue
- 79" Usable Width Inside
- Reflective Marker Tape
- Four D-Rings - 2 Per Side
- Floor Secured w/Torx Screws
- Two 5,200# Cambered EZ Lube Axles w/ Electric Brakes
- Complete Break-A-Way System w/Charger
- Spare Tire Mount
- 32" Dovetail
- 5' Stand-Up Ramps w/Support Leg
- Grommet Mount Sealed Lighting

Dimensions			
Length	A	B	C
14'	165"	103"	62"
16'	190"	115"	75"
18'	215"	127"	88"

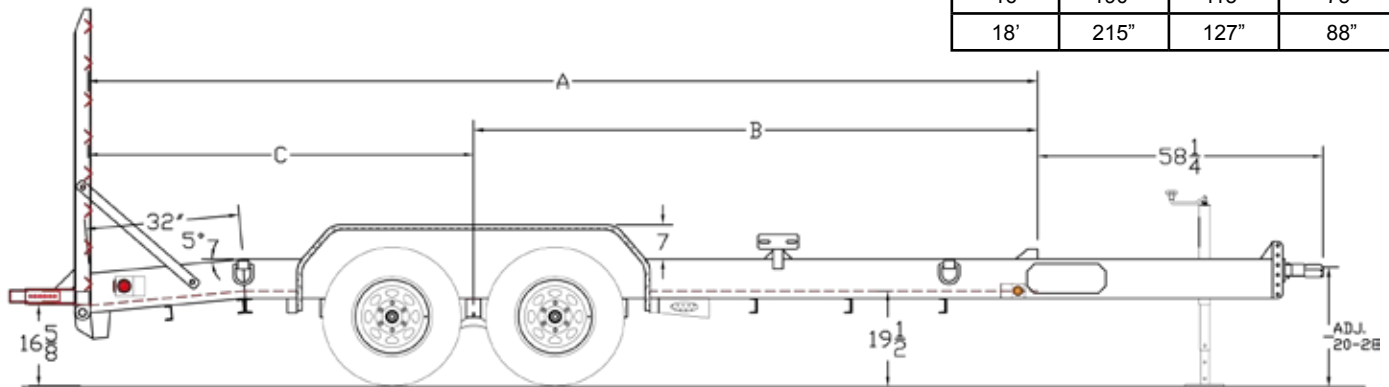

MODEL#	WEIGHT	DESCRIPTION
10EQ-14	2,460#	83" x 14' Tandem Axle Equipment Trailer
10EQ-16	2,600#	83" x 16' Tandem Axle Equipment Trailer
10EQ-18	2,660#	83" x 18' Tandem Axle Equipment Trailer

OPTIONS

12K Heavy Duty Drop Leg Jack	Tire Upgrade (7.50 x 16" LT LR-E)
Hydraulic Brakes 2 Axles	Spare Tire Upgrade (7.50 x 16" LT LR-E)
Spare Tire (ST225/75-15 LR-D)	