

10FT Pro Series Tilt Bed Equipment

G.V.W.R.	9,990#	AXLES	Two 5,200# EZ Lube w/Electric Brakes
G.A.W.R. (Ea. Axle)	5,200#	SUSPENSION	Multi-Leaf Spring with Equalizer
COUPLER	Adjustable Forged 2-5/16"	TIRE	ST225/75-15 Load Range D
SAFETY CHAINS	1/4" Grd. 70 w/Safety Latch Hook (2 each)	WHEEL	15 x 6 White Spoke 6-Bolt
JACK	7,000# Drop Leg Jack (Bolted On)	FLOOR	2" Pine
TONGUE	5" Channel Fold Back	LIGHTS	D.O.T. Stop, Tail, Turn & Clearance
TOP RAIL	None	ELEC. PLUG	7-Way RV
FRAME	6" Channel	FINISH (Prep)	Steel is Cleaned and Etched to Ensure Smooth, High Bond Paint Adhesion & Undercoated.
CROSSMEMBERS	3" Channel, 3" Sq. Tube	FINISH	Painted with High-Solids Supreme Automotive Grade Enamel and Pin-Striped for a Highly Decorative and Protective Finish.
UPRIGHTS	None		
FENDERS	10-3/4" x 72" Teardrop w/Back		

Standard Features

- Adjustable Forged Coupler
- Fold Back Tongue w/Raised Coupler
- Safety Chains Attached w/Cold Rolled Eyelets
- 7K Drop Leg Jack (Bolted On)
- Lower Jack Support Plate
- Unique Two Piece Main Frame
- 102" Wide Overall, 80" Width Between Fenders
- Tilt Platform is 75" Wide
- Hydraulic Dampening System
- Reflective Marker Tape
- Cambered EZ Lube Axles
- Two 5,200# Axles w/2 Electric Brakes
- Complete Break-A-Way System w/Charger
- Spare Tire Mount
- 1/4" Diamond Plate Knife Edge
- Grommet Mount Sealed Lighting

Dimensions				
Length	A	B	C	D
16'	202-1/2"	101"	101-1/2"	13°
18'	225-1/2"	113"	112-1/2"	12°
20'	249-1/2"	128"	121-1/2"	11°

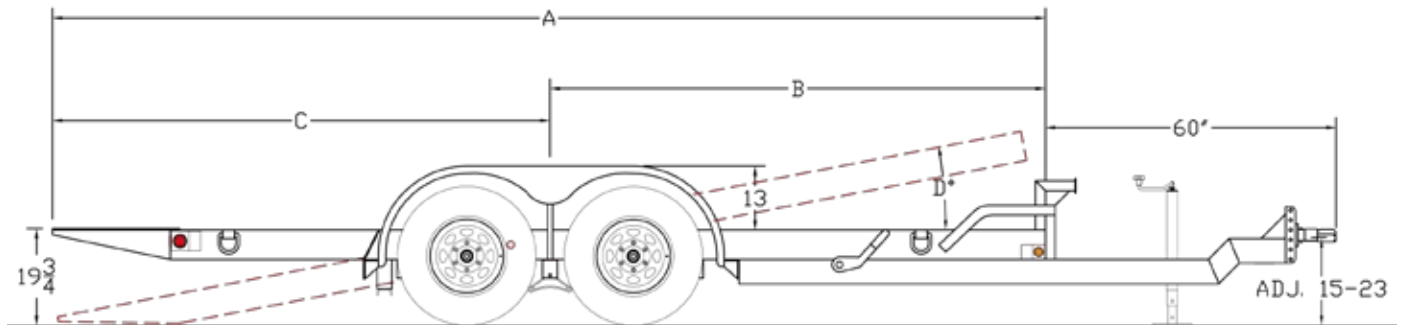

MODEL#	WEIGHT	DESCRIPTION
10FT-16	2,850#	80" x 16' Tilt Trailer
10FT-18	3,070#	80" x 18' Tilt Trailer
10FT-20	3,120#	80" x 20' Tilt Trailer

OPTIONS

Adjustable Pintle in Channel	Tire Upgrade (7.50 x 16" LT LR-E)
Hydraulic Brakes 2 Axles	Spare Tire Upgrade (7.50 x 16" LT LR-E)
Spare Tire (ST225/75-15 LR-D)	