

10TL Pro Series Tilt Bed Equipment

G.V.W.R.	9,990#	AXLES	Two 5,200# EZ Lube w/Electric Brakes
G.A.W.R. (Ea. Axle)	5,200#	SUSPENSION	Multi-Leaf Spring w/Equalizer
COUPLER	Adjustable Forged 2-5/16"	TIRE	ST225/75-15 Load Range D
SAFETY CHAINS	1/4" Grd. 70 w/Safety Latch Hook (2 each)	WHEEL	15" White, Spoke 6-Bolt
JACK	7,000# Drop Leg Jack (Bolted On)	FLOOR	2" Pine
TONGUE	5" Channel Fold Back	LIGHTS	D.O.T. Stop, Tail, Turn & Clearance
TOP RAIL	None	ELEC. PLUG	7-Way RV
FRAME	6" Channel	FINISH (Prep)	Steel is Cleaned and Etched to Ensure Smooth, High Bond Paint Adhesion & Undercoated.
CROSSMEMBERS	3" Channel, 3" Sq. Tube	FINISH	Painted with High-Solids Supreme Automotive Grade Enamel and Pin-Striped for a Highly Decorative and Protective Finish.
FENDERS	10-3/4" x 72" Teardrop w/Back		

Standard Features

- Adjustable Forged Coupler
- Fold Back Tongue w/Raised Coupler
- Safety Chains Attached w/Cold Rolled Eyelets
- 7K Drop Leg Jack (Bolted On)
- Lower Jack Support Plate
- Unique Two Piece Main Frame
- 102" Wide Overall, 80" Width Between Fenders
- Tilt Platform is 75" Wide
- Hydraulic Dampening System
- Reflective Marker Tape
- Floor Secured w/Torx Screws
- Cambered EZ Lube Axles
- Two 5,200# Axles w/2 Electric Brakes
- Complete Break-A-Way System w/Charger
- Spare Tire Mount
- 1/4" Diamond Plate Knife Edge
- Grommet Mount Sealed Lighting

Dimensions				
Length	A	B	C	D
20'	240-1/2"	128"	112-1/2"	192"

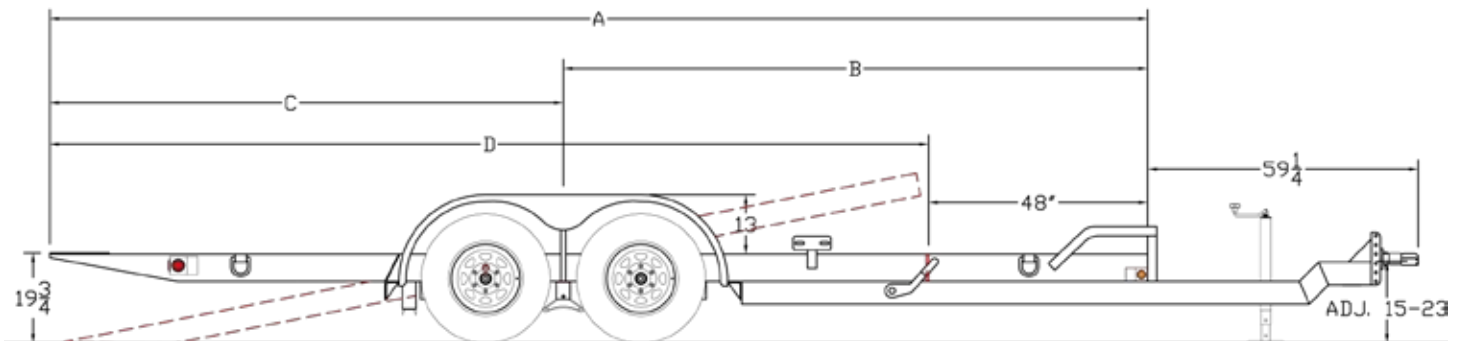

MODEL#	WEIGHT	DESCRIPTION
10TL-20	3,065#	80" x 20' (16' + 4') Tilt Trailer

OPTIONS

Adjustable Pintle in Channel	Tire Upgrade (7.50 x 16" LT LR-E)
Hydraulic Brakes 2 Axles	Spare Tire Upgrade (7.50 x 16" LT LR-E)
Spare Tire (ST225/75-15 LR-D)	