

60TP Single Axle Pan Tilt Transport

G.V.W.R.	6,000#	AXLE	6,000# EZ Lube Torflex Electric Brake
G.A.W.R. (Ea. Axle)	6,000#	SUSPENSION	Torsion
COUPLER	Adjustable Forged 2-5/16"	TIRE	ST235/16 - Load Range E
SAFETY CHAINS	1/4" Grd. 70 w/Safety Latch Hook (2 each)	WHEEL	16 x 6 White Spoke 8 Bolt
JACK	2,000# Swivel Mount	LIGHTS	D.O.T. Stop, Tail, Turn & Clearance
TONGUE	4" x 2" Square Tubing	ELEC. PLUG	7-Way RV
BED	3/16" Steel Pan	FINISH (Prep)	Steel is Cleaned and Etched to Ensure Smooth, High Bond Paint Adhesion.
CROSSMEMBERS	3" Channel	FINISH	Painted with High-Solids Supreme Automotive Grade Enamel and Pin-Striped for a Highly Decorative and Protective Finish.
FENDERS	16 Ga. Jeep Style		

Standard Features

- Fold Up Jack
- Safety Chains Attchd w/Cold Rolled Eyelets
- Safety Reflective Marker Tape
- 1 Piece 3/16" Formed Pan
- Texturized Floor for Increased Traction
- 78" Inside Dimension
- Four D-Rings (Inside Pan)
- 6,000# Axle w/Electric Brake
- Cambered EZ Lube Torsion Axles
- Complete Break-A-Way System w/Battery & Charger
- Tilt Bed w/Heavy Duty Latch
- 11 Degree Tilt Angle
- Grommet Mount Sealed Lighting

Dimensions With Dovetail			
Length	A	B	C
12'	144"	70"	74"

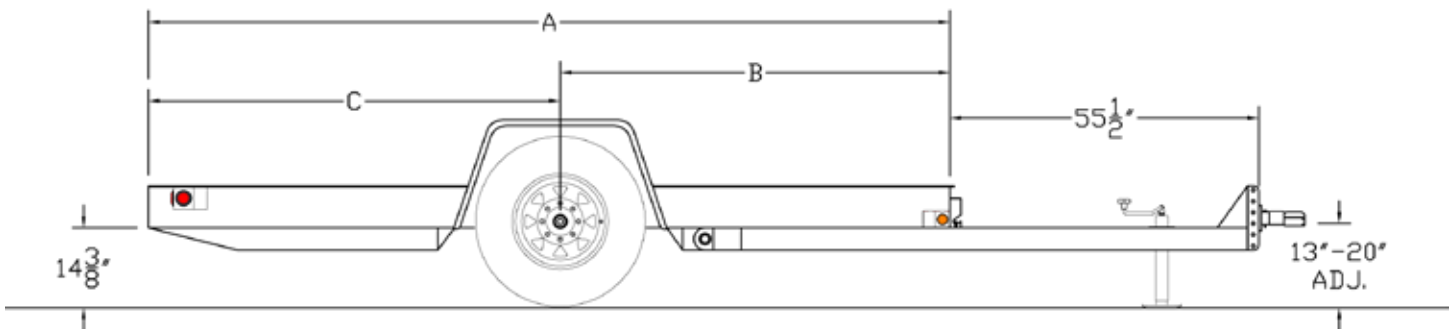

MODEL#	WEIGHT	DESCRIPTION
60TP-12	1,730#	78" x 12' Equipment Transport

OPTIONS

Adjustable 3" Pintle	Spare Tire (ST235/16 LR-E)
Hydraulic Surge Brakes on One Axle	Spare Tire Mount (Vertical on Tongue)