

15AA

Single Axle All-Around Utility

G.V.W.R.	1,500#	AXLE	2,000# EZ Lube
G.A.W.R.	1,500#	SUSPENSION	Multi-Leaf Slipper Spring
COUPLER	2"	TIRE	20.5 x 8.0-10 Load Range C
SAFETY CHAINS	1/4" Grd. 30 w/Safety Latch Hook (2 each)	WHEEL	10 x 6 - 5 Bolt
JACK	None	FLOOR	Expanded Metal
TONGUE	Single 3" x 2" Tubing (Cold Formed)	LIGHTS	D.O.T. Stop, Tail, Turn & Clearance
FRAME	2" x 2" x 1/8" Angle	FINISH (Prep)	Steel is Cleaned and Etched to Ensure Smooth, High Bond Paint Adhesion.
CROSSMEMBERS	2" x 2" x 1/8" Angle	FINISH	Painted with High-Solids Supreme Automotive Grade Enamel and Pin-Striped for a Highly Decorative and Protective Finish.
FENDERS	9" x 26" Jeep Style		
SIDES	14 Gauge Fabricated Smooth		
UPRIGHTS	11" Tall, 2" x 1" Tubing		

Standard Features

- Safety Chains Attached w/Cold Rolled Eyelets
- Cold Formed Tubular Raised Tongue
- Lower Tongue Support & Handle
- 12-1/2" Solid Fabricated Sides
- Expanded Metal Floor for Easy Cleaning
- 4 Tie Down Loops Inside
- EZ Lube Axle

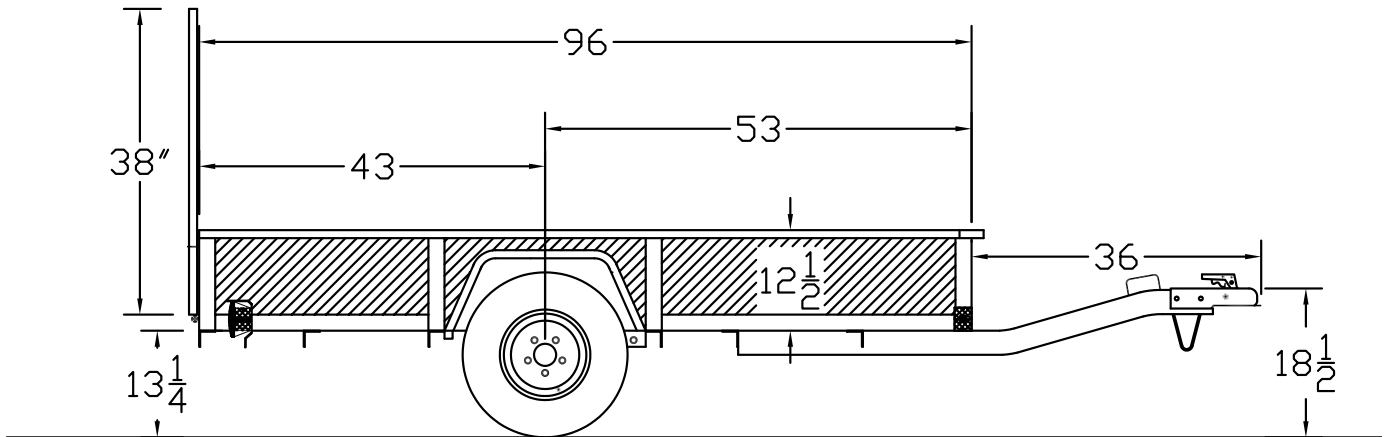

MODEL#	WEIGHT	DESCRIPTION
15AA-08	420#	50" x 8' Single Axle All-Around

OPTIONS

3' Rampgate w/Expanded Metal

STANDARD MODEL - NO OTHER OPTIONS AVAILABLE