

19SV Vanguard

G.V.W.R. 1,995#	AXLE 2,000# EZ Lube
G.A.W.R. 1,995#	SUSPENSION Multi-Leaf Spring
COUPLER 2" A-Frame	TIRE ST175/80-13" Load Range C
SAFETY CHAINS 1/4" Grd. 30 w/Safety Latch Hook (2 each)	WHEEL 13 x 4.5 White Spoke 5 Bolt
JACK 2,000# Top Wind (Bolted On)	FLOOR 2" Pine
TONGUE 3" Channel	LIGHTS D.O.T. Stop, Tail, Turn & Clearance
TOP RAIL 1-1/4" x 1-3/4" Pre-Formed Tube	ELEC. PLUG 4-Way Flat w/Loom
FRAME 3" x 2" x 3/16" Angle	FINISH (Prep) Steel is Cleaned and Etched to Ensure Smooth, High Bond Paint Adhesion.
CROSSMEMBERS 2" x 2" x 1/8" Angle	FINISH Painted with High-Solids Supreme Automotive Grade Enamel and Pin-Striped for a Highly Decorative and Protective Finish.
UPRIGHTS 2" x 2" x 1/8" Angle	
FENDERS 8" x 28" Rolled Formed	

Standard Features

- Safety Chains Attached w/Cold Rolled Eyelets
- Lower Jack Support Plate
- 4 Tie Down Loops Inside Bed
- Sand Foot on Jack
- 27-3/4" Sides w/ 24" V-Crimped Steel Panels
- EZ Lube Axle

Shown with Optional Gate

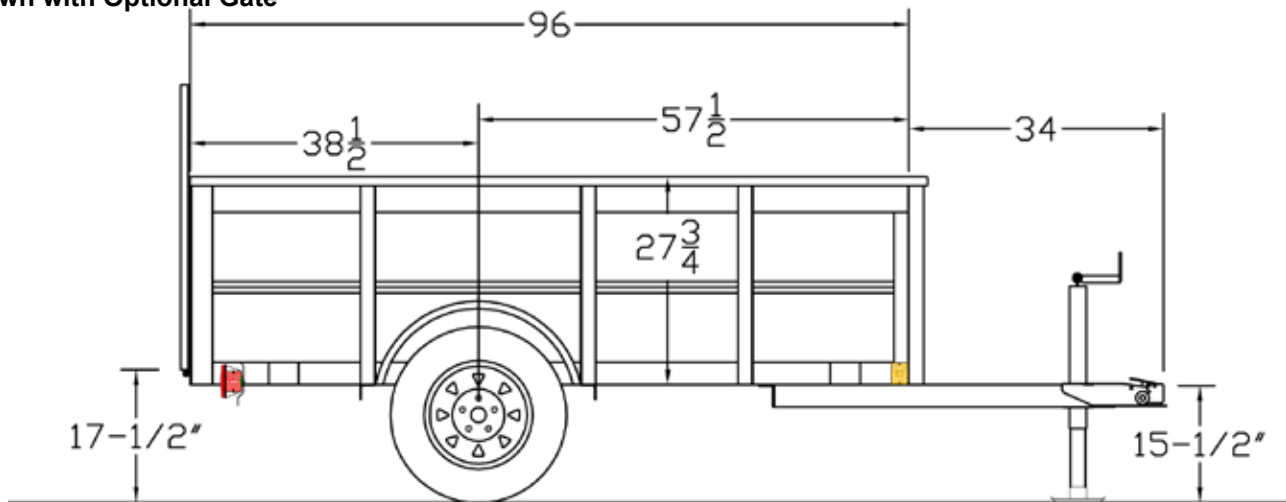

MODEL#	WEIGHT	DESCRIPTION
19SV-08	690#	50" x 8' Single Axle Vanguard

OPTIONS

3' Rampgate w/Expanded Metal