

# 30SV / 35SV Single Axle Vanguard

<b>G.V.W.R.</b>	2,995#	<b>AXLE</b>	3,500# EZ Lube w/Brake Flanges
<b>G.A.W.R.</b>	2,995#	<b>SUSPENSION</b>	Multi-Leaf Spring
<b>COUPLER</b>	2" A-Frame	<b>TIRE</b>	ST205/75-15 Load Range C
<b>SAFETY CHAINS</b>	1/4" Grd. 30 w/Safety Latch Hook (2 each)	<b>WHEEL</b>	15 x 5 White Spoke 5 Bolt
<b>JACK</b>	2,000# Top Wind (Bolted On)	<b>FLOOR</b>	2" Pine
<b>TONGUE</b>	3" Channel	<b>LIGHTS</b>	D.O.T. Stop, Tail, Turn & Clearance
<b>TOP RAIL</b>	2-3/8" Pipe	<b>ELEC. PLUG</b>	4-Way Flat w/Loom
<b>FRAME</b>	3" x 2" x 3/16" Angle	<b>FINISH (Prep)</b>	Steel is Cleaned and Etched to Ensure Smooth, High Bond Paint Adhesion.
<b>CROSSMEMBERS</b>	3" x 2" x 3/16" Angle	<b>FINISH</b>	Painted with High-Solids Supreme Automotive Grade Enamel and Pin-Striped for a Highly Decorative and Protective Finish.
<b>UPRIGHTS</b>	3" x 2" & 2" x 2" Angle, 26-3/4" Tall		
<b>FENDERS</b>	9" x 32" Rolled Formed		

## Standard Features

- Safety Chains Attached w/Cold Rolled Eyelets
- Sand Foot on Jack
- Lower Jack Support Plate
- 26-3/4" Tall Sides w/24" V-Crimped Steel Panels
- 4-Tie Down Loops Inside Bed
- Top Rail Capped w/Self Sealing Plugs
- Floor Secured w/Torx Screws
- EZ Lube Axle
- Grommet Mount Sealed Lighting

### Shown with Optional Gate

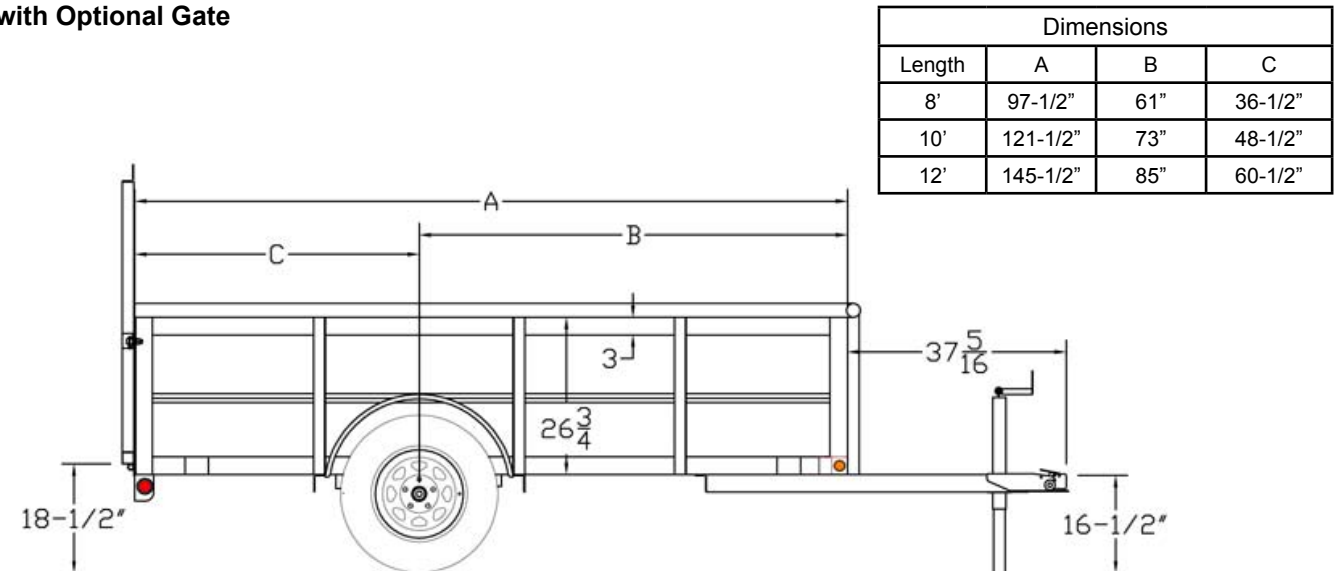

MODEL#	WEIGHT	DESCRIPTION
30SV-08	880#	60" x 8' Single Axle Vanguard
30SV-10	960#	60" x 10' Single Axle Vanguard
30SV-12	1,130#	60" x 12' Single Axle Vanguard
35SV-10	1,100#	77" x 10' Single Axle Vanguard
35SV-12	1,290#	77" x 12' Single Axle Vanguard

### OPTIONS

2" Forged Coupler	Spare Tire (ST205/75-15 LR-C)
2K Fold-Up Jack	4' Rampgate 5 W - 3 Center Uprights
Set Back Jack	4' Rampgate 6.5 W - 4 Center Uprights
Electric Brakes w/Complete Break-Away Kit	Gas Spring Assist Option - Rampgate
Spare Tire Mount (Side)	Removable Landscape Box - 24" x 24" x Width of Trailer