

# 12PI Heavy Duty Pipe Tandem Axle

<b>G.V.W.R.</b> 12,000#	<b>AXLES</b> Two 6,000# EZ Lube w/Electric Brakes
<b>G.A.W.R. (Ea. Axle)</b> 6,000#	<b>SUSPENSION</b> Multi-Leaf Slipper Spring w/Equalizer
<b>COUPLER</b> Forged 2-5/16" A-Frame	<b>TIRE</b> 7.50 x 16"LT Load Range E
<b>SAFETY CHAINS</b> 1/4" Grd. 70 w/Safety Latch Hook (2 each)	<b>WHEEL</b> 16 x 6 White Spoke 8 Bolt
<b>JACK</b> 7,000# Drop Leg Jack (Bolted On)	<b>FLOOR</b> 2" Pine
<b>TONGUE</b> 5" Channel Fold Back	<b>LIGHTS</b> D.O.T. Stop, Tail, Turn & Clearance
<b>TOP RAIL</b> 2-7/8" Pipe Square Back	<b>ELEC. PLUG</b> 7-Way RV
<b>FRAME</b> 5" x 3" x 1/4" Angle	<b>FINISH (Prep)</b> Steel is Cleaned and Etched to Ensure Smooth, High Bond Paint Adhesion & Undercoated.
<b>CROSSMEMBERS</b> 3" x 2" x 3/16" Angle	<b>FINISH</b> Painted with High-Solids Supreme Automotive Grade Enamel and Pin-Striped for a Highly Decorative and Protective Finish.
<b>UPRIGHTS</b> 16" Tall - 3" x 2" x 3/16" Angle	
<b>FENDERS</b> 9" x 72" Double Broke Diamond Plate w/ Back	

### Standard Features

- Forged Coupler
- Safety Chains Attached w/Cold Rolled Eyelets
- 7K Drop Leg Jack
- Lower Jack Support Plate
- Fold Back Tongue (14' and longer)
- Reflective Marker Tape
- Tie Down Pockets, Sides & Rear
- 2-7/8" Pipe Top Rail Capped w/Self Sealing Plugs
- Floor Secured w/Torx Screws
- Cambered EZ Lube Axles
- Two 6,000# Cambered Axles w/2 Electric Brakes
- Complete Break-A-Way System w/Charger
- Spare Tire Mount (Side)
- 4' Slide-In Ramps (Channel)
- Grommet Mount Sealed Lighting

Dimensions			
Length	A	B	C
16'	193-1/2"	115"	78-1/2"
18'	217-1/2"	127"	90-1/2"
20'	240"	138"	102"

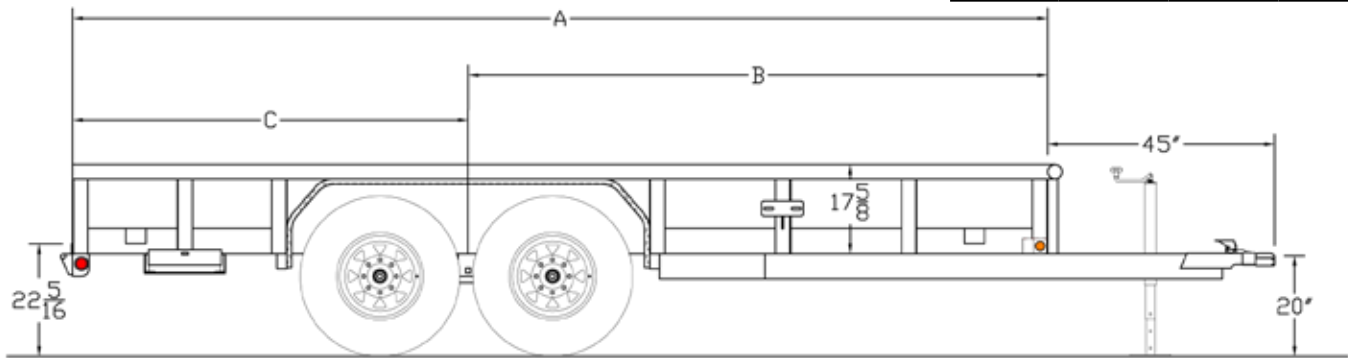

MODEL#	WEIGHT	DESCRIPTION
12PI-16	2,470#	83" x 16' Tandem Axle
12PI-18	2,560#	83" x 18' Tandem Axle
12PI-20	2,670#	83" x 20' Tandem Axle

### OPTIONS

12K Top Wind Drop Leg Jack	Rampgate in Lieu of Ramps
Hydraulic Brakes 2 Axles	Gas Spring Assist Option - Rampgate
Spare Tire (7.50 x 16" LT LR-E)	4' Heavy Duty Integrated Ramp Gate w/Gas Spring Assist In Lieu of Slide In Ramps
Tire Upgrade (ST235/16 LR-E)	
Spare Tire Upgrade (ST235/16 LR-E)	