

## Disc Brake: 8 Bolt, 6.5" Bolt Circle

AXLE  
COMPONENTS

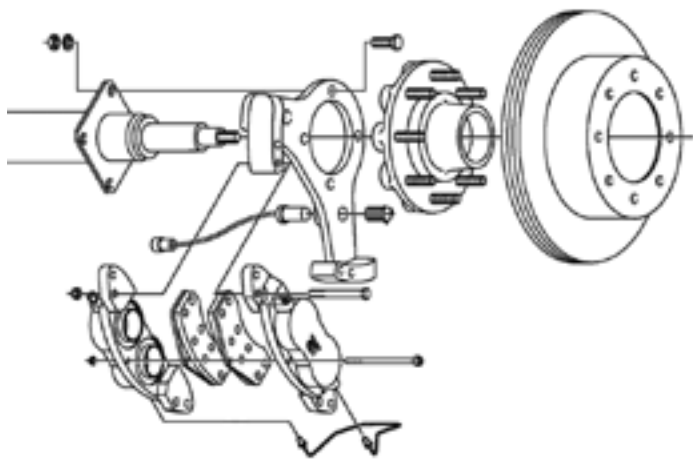

- **25580 Inner / 02475 Outer Bearings & Nev-R-Lube**
- Fits Dexter and most other 8,000 lb. axles
- Complete Disc Conversion Kits & Components
- Oil Bath, E-Z Lube & Nev-R-Lube Applications
- Two-Piece Hub/Rotor Design
- 9/16" or 5/8" Studs



PART NO.	REF. NO.	DESCRIPTION
K71-635*	193160	DEXTER 8K DISC KIT, 1 WHEEL, LESS HUB
8-399-90**	193165	DEXTER 8K DISC HUB KIT 9/16" STUD, EZ LUBE
8-399-91**	193170	DEXTER 8K DISC HUB KIT 9/16" STUD, OIL BATH
8-399-92**	193175	DEXTER 8K DISC HUB KIT 5/8" STUD, EZ LUBE
8-399-93**	193180	DEXTER 8K DISC HUB KIT 5/8" STUD, OIL BATH
8-402-80	193182	DEXTER 8K DISC NEV-R-LUBE HUB W/BEARING & RETAINER, 9/16" STUD
8-402-81	193183	DEXTER 8K DISC NEV-R-LUBE HUB W/BEARING & RETAINER, 5/8" STUD
K71-630	193218	REP'L CALIPER, W/CALIPER BOLTS (1 WHEEL) 8K
K71-631	193206	REP'L DISC ROTOR, DEX 8K
K71-629	193217	REP'L DISC PAD KIT, DEX 6K-8K (ONE AXLE)
31-71-3	130875	NEV-R-LUBE CARTRIDGE BEARING, 50MM X 84MM X 54MM
25580	130800	INNER BEARING
02475	131000	OUTER BEARING
25520	136200	INNER RACE
02420	137000	OUTER RACE
10-63	161225	UNITIZED OIL SEAL (3.376" O.D., 2.25" I.D.)
10-36	159700	GREASE SEAL (3.376" O.D., 2.25" I.D.), FOR E-Z LUBE, DOUBLE LIP
21-43-1	152400	GREASE CAP, 2.72" O.D., DRIVE-IN, FOR E-Z LUBE
85-1	155400	GREASE CAP PLUG FOR E-Z LUBE
RG04-230	150940	OIL CAP KIT (21-35 CAP, 10-45 O-RING, 46-32 PLUG)
7-257	145310	DRIVE-IN STUD, 9/16" DIA., 2.50" LONG
7-115	145600	DRIVE-IN STUD, 5/8" DIA., 3.16" LONG
6-53	140800	9/16" CONE WHEEL NUT
6-109	141000	5/8" CONE WHEEL NUT
95188	141600	5/8" FLANGE WHEEL NUT

\* Disc Kit includes 1ea. 8K Rotor, Caliper, Disc Pads, Bracket, & Hardware for Standard Grease or E-Z-Lube Axle Conversions to one side of axle beam.

\*\* Disc Hub Kits include Inner/Outer Bearing, Seal & Dust Cap.

## Grease Seals, Oil Seals and Wear Sleeves

PART NO.	REF. NO.	DESCRIPTION	I.D.	O.D.	USE WITH:
34823	157800	SINGLE LIP SEAL	1.249	1.983	BT8 SPINDLES
12192TB	157805	DOUBLE LIP SEAL	1.249	1.983	BT8 SPINDLES
13194	157810	SINGLE LIP SEAL	1.372	1.983	UNIQUE BT HUBS
10-9	158000	SINGLE LIP SEAL	1.500	1.987	BTR SPINDLES
10-60	158200	DOUBLE LIP SEAL	1.500	1.987	E-Z LUBE 2,000 LB
1105-100-031	158400	SINGLE LIP SEAL	1.750	2.356	10" HADCO
10-42	158600	SINGLE LIP SEAL	1.750	2.312	DEX 2,800 LB AXLES
168233	158750	SINGLE LIP SEAL	1.688	2.332	UNIQUE #84 HUBS
10-40	158775	SINGLE LIP SEAL	1.938	2.510	MHU AXLES
58846	158800	SINGLE LIP SEAL	1.719	2.565	3,500 LB AXLES
10-19	159000	DOUBLE LIP SEAL	1.719	2.565	E-Z LUBE 3,500 LB
29031	159200	SINGLE LIP SEAL	1.875	3.000	#8 SPINDLE
1105-100-035	159400	SINGLE LIP SEAL	2.00	2.875	2" HADCO
21325	159500	SINGLE LIP SEAL	2.125	3.269	UNIQUE #42 HUBS
42385	159600	SINGLE LIP SEAL	2.250	3.376	#42 SPINDLE
10-36	159700	DOUBLE LIP SEAL	2.250	3.376	E-Z LUBE END UNITS
10-1	159800	SINGLE LIP SEAL	2.125	3.375	DEX 5.2K - 7K LB
10-10	160000	DOUBLE LIP/OIL SEAL	2.125	3.376	E-Z LUBE & OIL 5.2K, 6K & 7K LB AXLES
T51153	160200	SINGLE LIP SEAL	2.375	3.623	#99 SPINDLE
SL150	160400	SINGLE LIP SEAL	1.500	2.332	AGRICULTURAL HUB
SL175	160600	SINGLE LIP SEAL	1.750	2.722	AGRICULTURAL HUB
SL200	160800	SINGLE LIP SEAL	2.000	3.066	AGRICULTURAL HUB
SL226	161000	SINGLE LIP SEAL	2.250	3.066	AGRICULTURAL HUB
SL275	161200	SINGLE LIP SEAL	2.750	3.756	AGRICULTURAL HUB
10-63	161225	UNITIZED OIL SEAL	2.250	3.376	DEX 8K (& 9K, 'TIL 10/89)
9103309	161227	DOUBLE LIP, DOUBLE CASE	2.250	3.376	8K HAYES
10-48	161230	OIL SEAL	2.375	3.376	OLD STYLE 8K
10-51	161650	UNITIZED OIL SEAL	2.875	3.880	DEX 9K, 10K GD
10-56	162000	UNITIZED OIL SEAL	3.125	4.500	DEX 10K, 12K, 15K & HAYES
382-8005	162410	OIL SEAL W/SLEEVE	2.775	3.671	INCLUDES 2.671 I.D. WEAR SLEEVE
10-55-1	162800	UNITIZED OIL SEAL	4.625	6.000	20K - 25K AXLES
91030	163000	UNITIZED OIL SEAL	2.750	3.779	HAYES #99 SPINDLE

AXLE  
COMPONENTS



## Grease Seals



Packaged double lip seals provide extra protection and longer life than standard single lip seals. Two per package.

PART NO.	REF. NO.	SEAL	I.D.	INTERCHANGE#
RG06-010	157700	12192TB	1.249"	34823
RG06-020	157710	10-60	1.987"	10-9
RG06-050	157720	10-19	1.719	58846
RG06-070	157730	10-36	2.250"	42385
RG06-090	157740	10-10	2.125"	10-1



## Grease Caps & Cap Plugs



PART NO.	REF. NO.	DESCRIPTION	O.D.
1527	151000	DRIVE-IN, AG HUBS	1.957
46749	151200	DRIVE-IN, 2K & 3.5K AXLES	1.986
21-3-1	151400	DRIVE-IN, E-Z LUBE 2K & 3.5K AXLES	1.986
45896	151600	DRIVE-IN, 5.2K AXLES W/ 6 BOLT HUBS	2.440
21-1-1	151800	DRIVE-IN, E-Z LUBE 5.2K & 6K AXLES W/ 6 BOLT HUBS	2.440
1604	152000	DRIVE-IN, AG HUBS	2.440
38605	152200	DRIVE-IN, 5.2K, 6K & 7K AXLES, OLD STYLE "DOME CAP"	2.720
21-39	155300	DRIVE-IN, 5.2K, 6K & 7K AXLES, NEW STYLE & 35MM NEV-R-LUBE	2.720
21-43-1	152400	DRIVE-IN, E-Z LUBE 5.2K, 6K & 7K, 8 BOLT AXLES	2.720
1609	152600	DRIVE-IN, AG HUBS & 42MM NEV-R-LUBE	3.125
1602	152800	DRIVE-IN, VILLAGE 7K AXLES	3.250
75DC	153000	DRIVE-IN, #99 SPINDLES & 50MM NEV-R-LUBE	3.355
092105	153200	DRIVE-IN, HAYES 10K & 12K AXLES	3.625
85-1	155400	GREASE CAP PLUG, ALL E-Z LUBE CAPS	N/A

## Cap Driver Tools



Custom-sized specifically for trailer axle dust caps, this dust cap driver can be used for installation, removal, and servicing trailer hubs without denting the dust caps. Designed for ease of use by dust cap installers, no professional trailer service center will want to be without this handy tool.

PART NO.	REF. NO.	DESCRIPTION
151425	290-991	DUST CAP DRIVER/TOOL, (SM) FITS 46749, 21-3-1
151825	290-992	DUST CAP DRIVER/TOOL, (MED) FITS 45896, 21-1-1
152425	290-993	DUST CAP DRIVER/TOOL, (LG) FITS 21-39, 21-43-1

## Oil Cap Replacement Parts



PART NO.	REF. NO.	DESCRIPTION	FOR:
21-40	153600	2.563" O.D., SCREW-IN PLASTIC	6K, 7K OIL (5 SPOKE) DX
21-35	153800	2.875" O.D., SCREW-IN PLASTIC	6K-8K (& 9K PRIOR TO 10/89) DX
21-36	153975	4.00" O.D., SCREW-IN PLASTIC	9K (AFTER 10/89), 10K GD, 10K-15K DX
92128	154100	OIL CAP ONLY	7K-8K HAYES/ALKO NEW STYLE (AFTER 01/97)
9212801	154150	OIL CAP ONLY	7K-8K HAYES (PRIOR TO 01/97)
92125	154200	3.750" O.D., SCREW-IN	10K, 12K HAYES / ALKO
46-32	155600	OIL CAP PLUG	21-35, 21-36, 21-37 CAPS
92126	155800	OIL CAP PLUG	92125, 340-4009, 340-4139, 92128
46-52	156000	OIL HUB PLUG	8K-15K DEXTR OIL HUBS
10-45	156600	OIL CAP O-RING	21-35 OIL CAP
10-50	156800	OIL CAP O-RING	21-36 CAP
10-59	156825	OIL CAP O-RING	21-40 OIL CAP
92127	157000	OIL CAP O-RING	92125 OIL CAP
9103501	153985	OIL CAP GASKET	92128 & 9212801
9103502	153990	OIL CAP GASKET	92125 (USE W/ 92127 O-RING)

## Bolt-On Oil Caps



PART NO.	REF. NO.	DESCRIPTION
340-4139	157400	OIL CAP, 6 ON 4.06" BOLT, FOR HAYES 10K OLD STYLE
340-4009	157600	OIL CAP, 6 ON 5 1/2" BOLT, FOR 20K - 25K AXLES

**Redline** SM **Packaged Grease Caps**  
 TRAILER REPAIR PARTS

Protect bearings from contamination with packaged grease caps.  
 Two caps per package.

PART NO.	REF. NO.	DESCRIPTION
RG04-010	150900	PLUG ONLY FOR E-Z LUBE GREASE CAPS
RG04-020	150905	1.986" O.D., DRIVE-IN
RG04-040	150910	1.986" O.D., DRIVE-IN W/ PLUG FOR E-Z LUBE
RG04-060	150915	2.44" O.D., DRIVE-IN
RG04-080	150920	2.44" O.D., DRIVE-IN W/ PLUG FOR E-Z LUBE
RG04-100	150925	2.72" DRIVE-IN
RG04-120	150930	2.72" DRIVE-IN W/ PLUG FOR E-Z LUBE



AXLE  
 COMPONENTS

**Complete Oil Cap Kits**

PART NO.	REF. NO.	DESCRIPTION	FITS:
RG04-230	150940	21-35 OIL CAP, 10-45 O-RING 46-32 PLUG	6K, 7K 8K, 9K AXLES (8-BOLT) DEXTER
RG04-250	150945	92125 OIL CAP, 92127 O-RING 9103502 GASKET, 92126 PLUG	10K 12K HAYES / ALKO
RG04-260	150950	21-40 OIL CAP, 10-59 O-RING	6K 7K, OIL BATH HUB & DRUMS (5-SPOKE)
RG04-270	150955	21-36 OIL CAP, 10-50 O-RING, 46-32 PLUG	9K (AFTER 10/89) & 10K GD
RG04-280	150960	92128 OIL CAP, 9103501 GASKET, 92126 PLUG	8K HAYES / ALKO (AFTER 01/97)
RG04-290	150965	9212801 OIL CAP, 9103501 GASKET, 92126 PLUG	8K HAYES / ALKO (PRIOR 01/97)



**Bearing Protectors**

Bearing Protectors keep grease inside the hub and water out! An overload outlet allows grease to escape if the hub is overfilled or excessive pressure is built up. Fits 1.980" 2K-3.5K hubs with L44610 outer race. Chrome plated metal alloy construction. Bearing Protector Covers keep the excess grease from being thrown on the wheels while trailering.



RG07-040

PART NO.	REF. NO.	DESCRIPTION
BLB1	414000	BEARING PROTECTOR COVER, FITS 2.125" O.D., 1EA.
RG07-040	414001	PKGD 1.98" BEARING PROTECTORS & COVERS, 1 PAIR (2" O.D.)
RG07-045	414002	PKGD BRG PROTECTOR COVER, FITS 2"OD PROTECTORS, 1PAIR



RG07-045

See Pages B-39 thru B-40 for unpackaged items.